

Strain

- Relating strains to displacements is a problem in geometry.

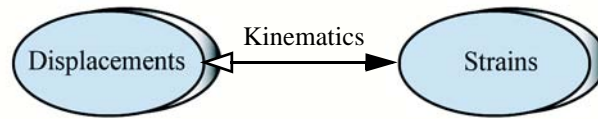

Learning objectives

- Understand the concept of strain.
- Understand the use of approximate deformed shape for calculating strains from displacements.

Preliminary Definitions

- The total movement of a point with respect to a fixed reference coordinates is called *displacement*.
- The relative movement of a point with respect to another point on the body is called *deformation*.
- *Lagrangian strain* is computed from deformation by using the original undeformed geometry as the reference geometry.
- *Eulerian strain* is computed from deformation by using the final deformed geometry as the reference geometry.

Average Normal Strain

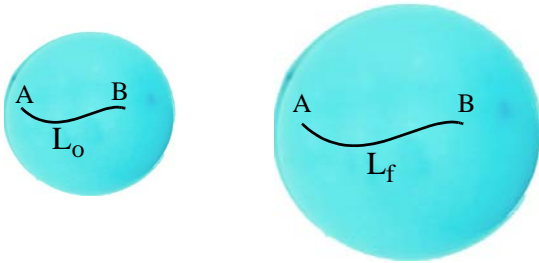

$$\epsilon_{av} = \frac{L_f - L_0}{L_0} = \frac{\delta}{L_0}$$

- Elongations ($L_f > L_0$) result in *positive* normal strains. Contractions ($L_f < L_0$) result in *negative* normal strains.

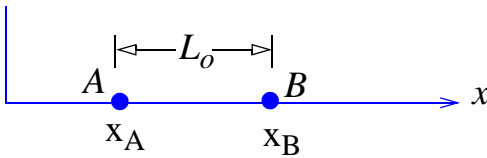

$$L_0 = x_B - x_A$$

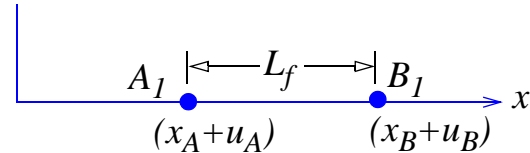

$$L_f = (x_B + u_B) - (x_A + u_A) = L_0 + (u_B - u_A)$$

$$\epsilon_{av} = \frac{u_B - u_A}{x_B - x_A}$$

Units of average normal strain

- To differentiate average strain from strain at a point.
- in/in, or cm/cm, or m/m
- percentage. 0.5% is equal to a strain of 0.005
- prefix: $\mu = 10^{-6}$. 1000 μ in / in is equal to a strain 0.001 in / in

C2.1 Due to the application of the forces in Fig. C2.1, the displacement of the rigid plates in the x direction were observed as given below. Determine the axial strains in rods in sections AB, BC, and CD.

$$u_B = -1.8 \text{ mm} \quad u_C = 0.7 \text{ mm} \quad u_D = 3.7 \text{ mm}$$

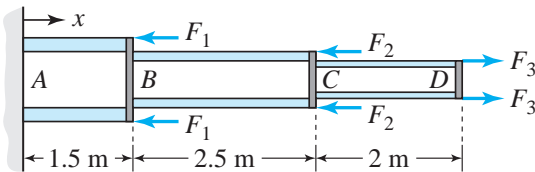
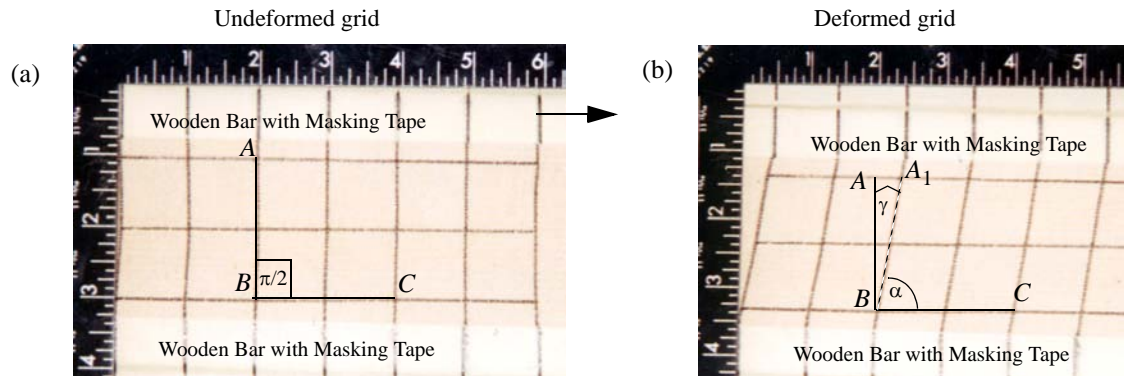

Fig. C2.1

Average shear strain



$$\gamma_{av} = \frac{\pi}{2} - \alpha$$

- Decreases in the angle ($\alpha < \pi / 2$) result in *positive* shear strain. Increase in the angle ($\alpha > \pi / 2$) result in *negative* shear strain

Units of average shear strain

- To differentiate average strain from strain at a point.
- rad
- prefix: $\mu = 10^{-6}$. 1000 μ rad is equal to a strain 0.001 rad

Small Strain Approximation

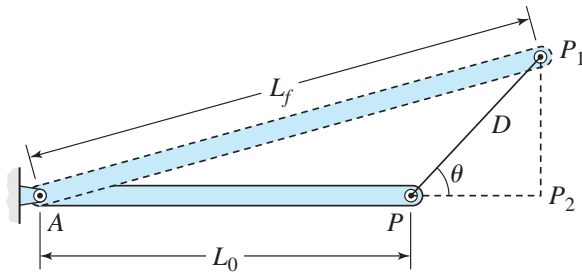

$$L_f = \sqrt{L_o^2 + D^2 + 2L_o D \cos \theta}$$

$$L_f = L_o \sqrt{1 + \left(\frac{D}{L_o}\right)^2 + 2\left(\frac{D}{L_o}\right) \cos \theta}$$

$$\epsilon = \frac{L_f - L_o}{L_o} = \sqrt{1 + \left(\frac{D}{L_o}\right)^2 + 2\left(\frac{D}{L_o}\right) \cos \theta} - 1 \tag{2.5}$$

$$\epsilon_{small} = \frac{D \cos \theta}{L_o} \tag{2.6}$$

ϵ_{small} Eq. 2.6	ϵ Eq. 2.5	% error
1.0	1.23607	19.1
0.5	0.58114	14.0
0.1	0.10454	4.3
0.05	0.005119	2.32
0.01	0.01005	0.49
0.005	0.00501	0.25

- Small-strain approximation may be used for strains less than 0.01
- Small normal strains are calculated by using the deformation component in the original direction of the line element regardless of the orientation of the deformed line element.
- In small shear strain (γ) calculations the following approximation may be used for the trigonometric functions: $\tan \gamma \approx \gamma$ $\sin \gamma \approx \gamma$ $\cos \gamma \approx 1$
- Small-strain calculations result in linear deformation analysis.
- Drawing approximate deformed shape is very important in analysis of small strains.

C2.2 A thin triangular plate ABC forms a right angle at point A. During deformation, point A moves vertically down by δ_A . Determine the average shear strain at point A.

$$\delta_A = 0.008 \text{ in}$$

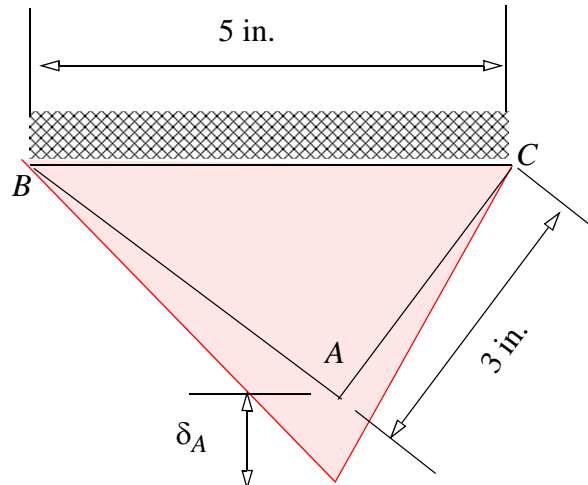

Fig. C2.2

C2.3 A roller at P slides in a slot as shown. Determine the deformation in bar AP and bar BP by using small strain approximation.

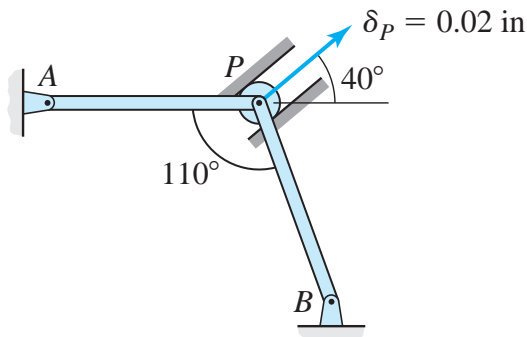
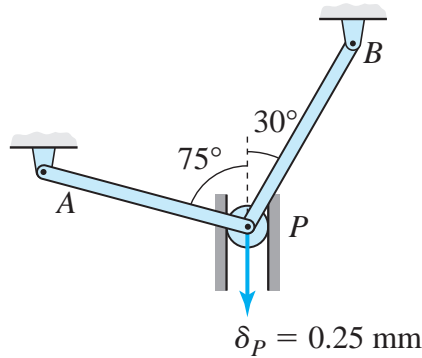

Fig. C2.3

Class Problem 1

Draw an approximate exaggerated deformed shape.

Using small strain approximation write equations relating δ_{AP} and δ_{BP} to δ_P .



Strain Components

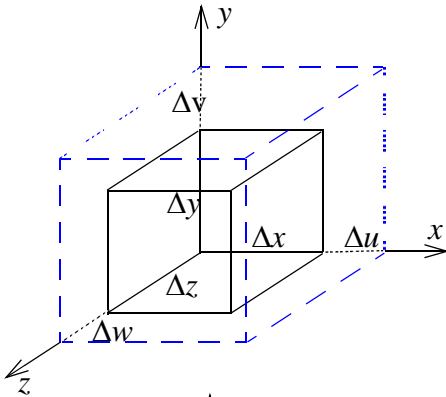

$$\epsilon_{xx} = \frac{\Delta u}{\Delta x}$$

$$\epsilon_{yy} = \frac{\Delta v}{\Delta y}$$

$$\epsilon_{zz} = \frac{\Delta w}{\Delta z}$$

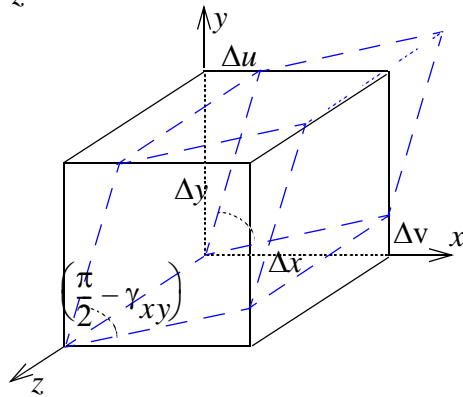

$$\gamma_{xy} = \frac{\Delta u}{\Delta y} + \frac{\Delta v}{\Delta x}$$

$$\gamma_{yx} = \frac{\Delta v}{\Delta x} + \frac{\Delta u}{\Delta y} = \gamma_{xy}$$

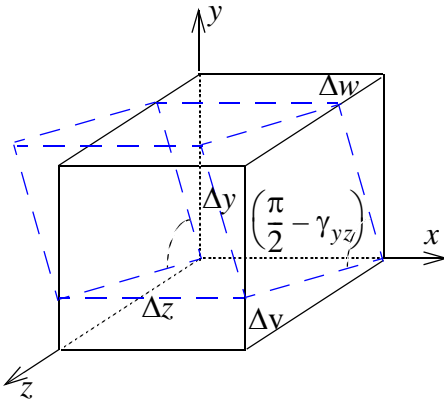

$$\gamma_{yz} = \frac{\Delta v}{\Delta z} + \frac{\Delta w}{\Delta y}$$

$$\gamma_{zy} = \frac{\Delta w}{\Delta y} + \frac{\Delta v}{\Delta z} = \gamma_{yz}$$

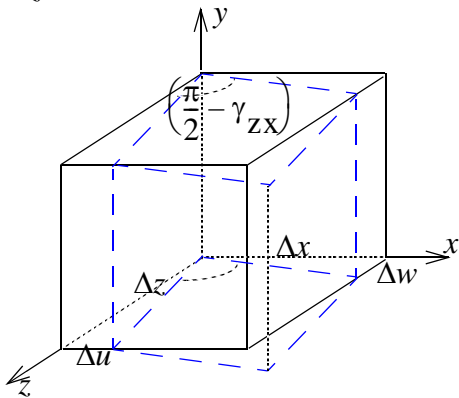

$$\gamma_{zx} = \frac{\Delta w}{\Delta x} + \frac{\Delta u}{\Delta z}$$

$$\gamma_{xz} = \frac{\Delta u}{\Delta z} + \frac{\Delta w}{\Delta x} = \gamma_{zx}$$

Engineering Strain

Engineering strain matrix

$$\begin{bmatrix} \varepsilon_{xx} & \gamma_{xy} & \gamma_{xz} \\ \gamma_{yx} & \varepsilon_{yy} & \gamma_{yz} \\ \gamma_{zx} & \gamma_{zy} & \varepsilon_{zz} \end{bmatrix}$$

Plane strain matrix

$$\begin{bmatrix} \varepsilon_{xx} & \gamma_{xy} & 0 \\ \gamma_{yx} & \varepsilon_{yy} & 0 \\ 0 & 0 & 0 \end{bmatrix}$$

Strain at a point

$$\varepsilon_{xx} = \lim_{\Delta x \rightarrow 0} \left(\frac{\Delta u}{\Delta x} \right) = \frac{\partial u}{\partial x}$$

$$\gamma_{xy} = \gamma_{yx} = \lim_{\substack{\Delta x \rightarrow 0 \\ \Delta y \rightarrow 0}} \left(\frac{\Delta u}{\Delta y} + \frac{\Delta v}{\Delta x} \right) = \frac{\partial u}{\partial y} + \frac{\partial v}{\partial x}$$

$$\varepsilon_{yy} = \frac{\partial v}{\partial y}$$

$$\gamma_{yz} = \gamma_{zy} = \frac{\partial v}{\partial z} + \frac{\partial w}{\partial y}$$

$$\varepsilon_{zz} = \frac{\partial w}{\partial z}$$

$$\gamma_{zx} = \gamma_{xz} = \frac{\partial w}{\partial x} + \frac{\partial u}{\partial z}$$

- tensor normal strains = engineering normal strains
- tensor shear strains = (engineering shear strains) / 2

Strain at a Point on a Line

$$\varepsilon_{xx} = \frac{du(x)}{dx}$$

C2.4 Displacements u and v in the x and y directions respectively were measured by Moire Interferometry method at many points on a body. Displacements of four points on a body are given below. Determine the average values of strain components ε_{xx} , ε_{yy} , and γ_{xy} at point A shown in Fig. C2.4.

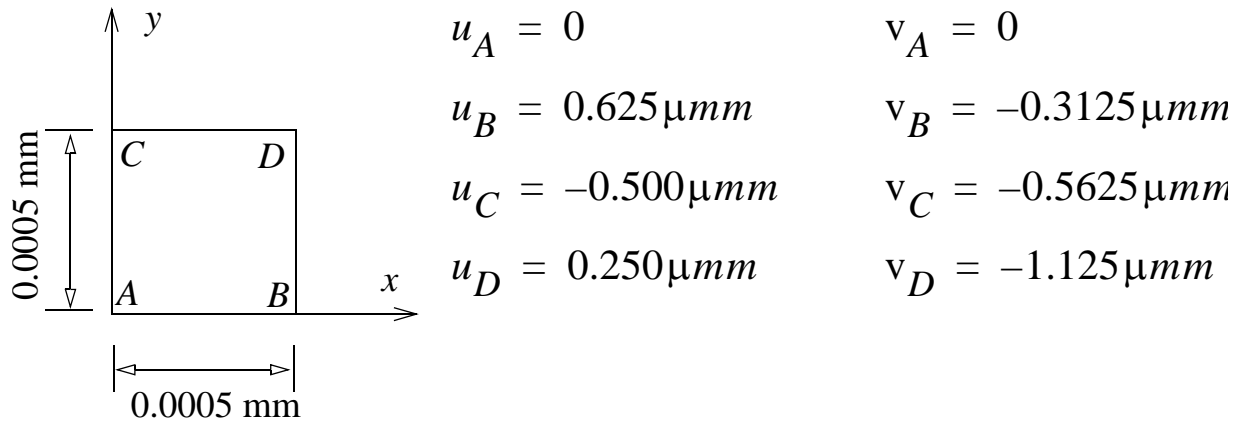
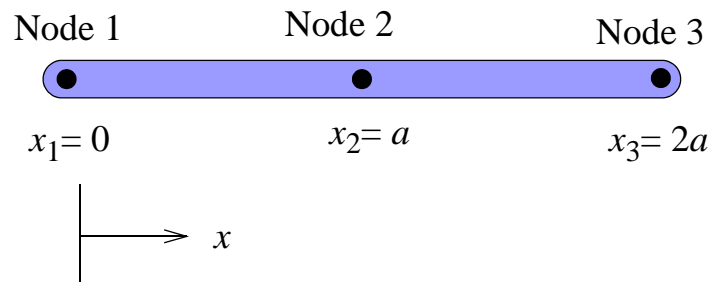

Fig. C2.4

C2.5 The axial displacement in a quadratic one-dimensional finite element is as given below.

$$u(x) = \frac{u_1}{2a^2}(x-a)(x-2a) - \frac{u_2}{a^2}(x)(x-2a) + \frac{u_3}{2a^2}(x)(x-a)$$

Determine the strain at Node 2.



C2.6 A metal strip is to be pulled and bent to conform to a rigid surface such that the length of strip between OA fits the arc OB of the surface. The equation of the surface $y = f(x)$ and the length OA is as given below. Determine the average normal strain in the metal strip.

$f(x) = (0.04x^{3/2} - 0.005x)$ inches and length OA = 9 inches. Use numerical integration

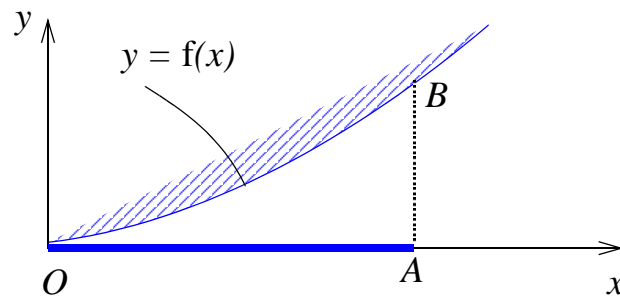

Fig. C2.6